

2LTA G2C100

Pyroelectric Dual Channel Detector for Measurement Applications

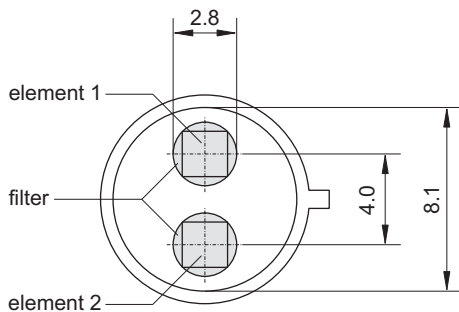
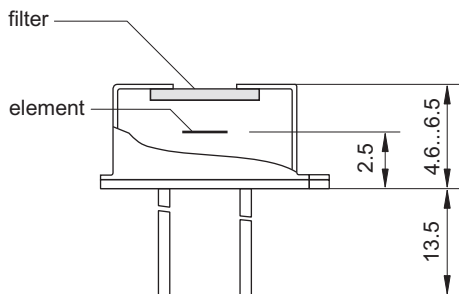
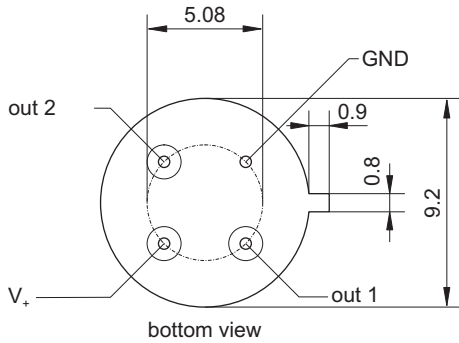

element size	2 mm × 2 mm
aperture	2.8 mm
filter ³	custom-designed
responsivity ^{1,2}	>70000 V/W
noise ¹	<20000 nV/√Hz
specific detectivity ^{1,2}	>2.5·10 ⁸ cm √Hz/W
offset voltage	<5 mV
operating voltage	2.2 V to 8 V
housing	TO 39
operating temperature	-20 to 70 °C
storage temperature	-20 to 70 °C

- 1) frequency: 10 Hz, detector temperature: 25 °C
- 2) black body source temperature: 500 K, filter transmission: 100 %
- 3) other filters on request

