

2LTA G2PC

Pyroelectric Dual Channel Detector for Measurement Applications

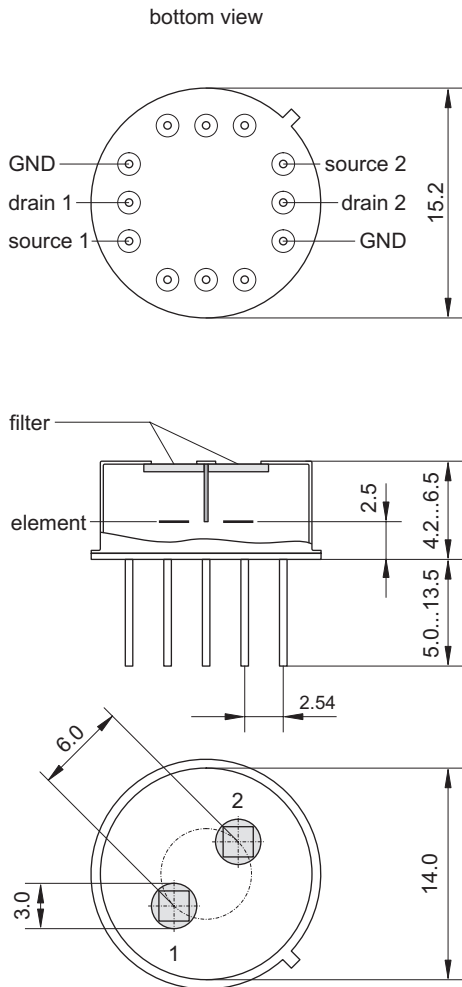

| | |
|-------------------------------------|-----------------------------|
| element size | 2 mm × 2 mm |
| aperture | 3.0 mm |
| filter ³ | custom-designed |
| responsivity ^{1,2} | >150 V/W |
| noise ¹ | <100 nV/√Hz |
| specific detectivity ^{1,2} | >3·10 ⁸ cm √Hz/W |
| thermal compensation | parallel |
| offset voltage | 0.4 to 1.5 V |
| operating voltage | 2 V to 18 V |
| housing | TO 8 |
| operating temperature | -20 to 70 °C |
| storage temperature | -20 to 70 °C |

- 1) frequency: 10 Hz, detector temperature: 25 °C
- 2) black body source temperature: 500 K, filter transmission: 100 %
- 3) other filters on request

