

LTA G2I100

Pyroelectric Single Element Detector for Measurement Applications

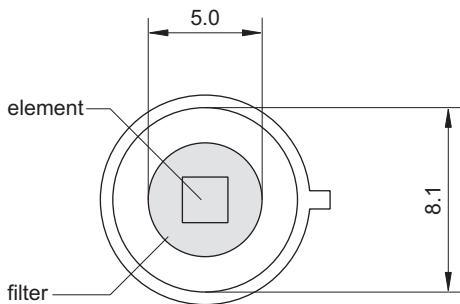
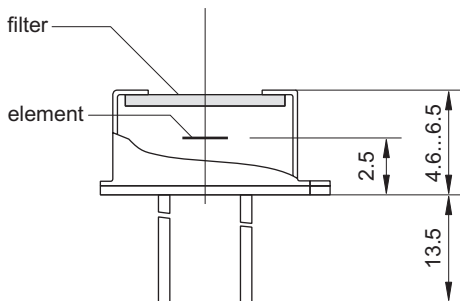
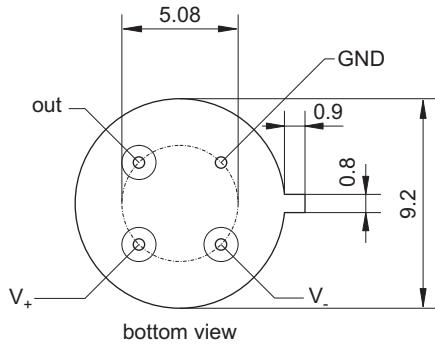

| | |
|-------------------------------------|-----------------------------------|
| element size | 2 mm × 2 mm |
| aperture | 5.0 mm |
| filter ³ | custom-designed |
| responsivity ^{1,2} | >70000 V/W |
| noise ¹ | <20000 nV/√Hz |
| specific detectivity ^{1,2} | >2.5 · 10 ⁸ cm √Hz / W |
| offset voltage | <5 mV |
| operating voltage | ±2.2 V to ±8 V |
| housing | TO 39 |
| operating temperature | -20 to 70 °C |
| storage temperature | -20 to 70 °C |

- 1) frequency: 10 Hz, detector temperature: 25 °C
- 2) black body source temperature: 500 K, filter transmission: 100 %
- 3) other filters on request

