

PYROVIEW 640G

High-resolution infrared camera for application in glass industry



- ✓ Precise non-contact temperature measurement from 200 °C to 1250 °C
- ✓ Uncooled microbolometer array with 640 × 480 pixels
- ✓ Spectral range 4.8 µm to 5.2 µm
- ✓ Numerous optics with motor focus
- ✓ Measurement frequency 50 frames per second
- ✓ Gigabit Ethernet interface (1 GBit/s)
- ✓ Large dynamic range and 16-Bit analog digital converter
- ✓ Camera in small housing „compact+“ (IP54) or industry protection housing "protection" (IP65)
- ✓ Integration in customized system solutions including hard- and software adjustment

Overview

Whether in process monitoring, process automation or quality control in float glass and container glass production – the infrared camera PYROVIEW 640G measures temperatures without contact exactly and reliably. Also in very fast processes or at temperature changes the data acquisition happens in real-time. For a high measurement accuracy the spectral range of the camera is optimally adjusted to measurement objects made from glass.

In stationary industrial continuous operation measurement data is recorded with high spatial resolution on fixed or moving measurement objects. In this way production processes are monitored and controlled efficiently.

Therefore the Gigabit Ethernet interface guarantees a data acquisition without loss and with no appreciable time delay up to 50 images per second. The maximum image frequency of 50 Hz is adjusted optimally to the thermal time constant of the infrared array.

Numerous motor focus infrared lenses, including wide angle and telephoto lenses, provide a flexible adjustment to different measurement object sizes at different measurement distances.

The infrared camera is either built in a small aluminium housing „compact+“ or in a stainless steel industry protection housing „protection“ that has a protection window, an air purge unit and an optional watercooling.

The camera observes the production in stand-alone operation without any connected computer via two galvanically isolated digital inputs and outputs. All process parameters of the stand-alone version are programmed once on location via PC connection.

The modular Windows software PYROSOFT of the camera can be adjusted and extended to process-related requirements. The free software PYROSOFT Compact is delivered with every PYROVIEW infrared camera.



Made by DIAS Infrared

DIAS Infrared headquartered in Dresden (Germany) develops and manufactures high-quality precision devices as well as system solutions for non-contact temperature measurement. Challenging projects are a welcoming motivation for us. The customers appreciate the robust make, outstanding accuracy, superb reliability and the high service standard of our equipment technology.

PYROVIEW 640G

High-resolution infrared camera for application in glass industry

Technical data		
Device type	640G compact+	640G protection
Spectral range ¹	4.8 μm to 5.2 μm	
Temperature ranges ¹	range 1: 200 °C to 500 °C, range 2: 400 °C to 1250 °C	
NETD ^{2,3}	< 1 K (400 °C, 50 Hz)	
Aperture angle ⁴ (HFOV × VFOV)	25° × 19°, optional: 75° × 60°, 59° × 46°, 43° × 33°, 12° × 9° (optics with motor focus)	
Sensor	uncooled microbolometer array (640 × 480 pixels)	
Measurement uncertainty ³	2 % of measured value °C	
Measurement frequency ⁵	internal 50 Hz, selectable: 50 Hz, 25 Hz, 12,5 Hz, ...	
Response time	internal 40 ms, selectable: 2 / measurement frequency	
Interfaces	Gigabit-Ethernet (real-time, 50 Hz), galvanically isolated digital inputs (trigger) and digital outputs (alarm)	
Connectors	round plug connector HR10A (12 pin, power supply, digital inputs and outputs), round plug connector M12A (Ethernet)	round plug connector M23 (16 pin, power supply, digital inputs and outputs), round plug connector M12A (Ethernet)
Power supply	12 V to 36 V DC, typical 10 VA	
Weight	approx. 1.6 kg	approx. 4.2 kg
Housing	aluminium compact housing IP54, 65 mm (L) × 160 mm (W) × 79 mm (H), without lens and connectors, optional with weather protection housing with pan-tilt-unit	industry protection housing IP65, stainless steel, with protection window, air purge and optional water cooling, diameter 110 mm, length 280 mm (without mechanical mounting and connectors), 6 bar max. water pressure, 2 bar max. air pressure
Operating temperature of the camera	-10 °C to 50 °C	-10 °C to 50 °C (without water cooling), -25 °C to 150 °C (with water cooling)
Storage conditions	-20 °C to 70 °C, max. 95 % rel. humidity	
Software	control and imaging software PYROSOFT for Windows®, customized modifications on request	
Scope of delivery	infrared camera PYROVIEW 640G, calibration certificate, manual, software PYROSOFT Compact	

¹ Others on request. ² Noise equivalent temperature difference. ³ Specifications for black body radiator and ambient temperature 25 °C. ⁴ Lens with motor focus.

⁵ Export version with < 9 Hz available.

Optics variants (optics with motor focus)

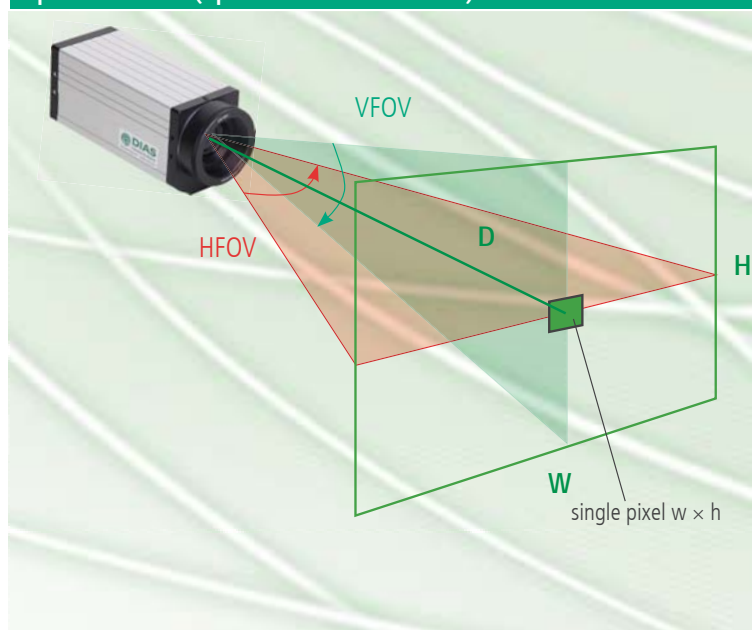

HFOV × VFOV	D [m]	W [m]	H [m]	w [mm]	h [mm]
25° × 19°	1	0.44	0.33	0.7	0.7
	3	1.31	0.98	2	2
	10	4.35	3.26	7	7
0.7 mrad	1	1.53	1.15	2.4	2.4
	3	4.60	3.46	7.2	7.2
	10	15.35	11.55	24	24
75° × 60°	1	1.13	0.85	1.8	1.8
	3	3.39	2.55	5.3	5.3
	10	11.32	8.49	17.7	17.7
2 mrad	1	0.79	0.59	1.2	1.2
	3	2.36	1.78	3.7	3.7
	10	7.88	5.92	12.3	12.3
59° × 46°	1	0.22	0.16	0.3	0.3
	3	0.65	0.49	1	1
	10	2.18	1.63	3	3
1.6 mrad	1	0.22	0.16	0.3	0.3
	3	0.65	0.49	1	1
	10	2.18	1.63	3	3
43° × 33°	1	0.22	0.16	0.3	0.3
	3	0.65	0.49	1	1
	10	2.18	1.63	3	3
1.2 mrad	1	0.22	0.16	0.3	0.3
	3	0.65	0.49	1	1
	10	2.18	1.63	3	3
12° × 9°	1	0.22	0.16	0.3	0.3
	3	0.65	0.49	1	1
	10	2.18	1.63	3	3
0.3 mrad	1	0.22	0.16	0.3	0.3
	3	0.65	0.49	1	1
	10	2.18	1.63	3	3

HFOV ... Horizontal Field Of View (horizontal aperture angle)

VFOV ... Vertical Field Of View (vertical aperture angle)

IFOV ... Instantaneous Field Of View (spatial resolution)

D ... Measurement distance

W ... Image width

H ... Image height

w ... Pixel width

h ... Pixel height

PYROVIEW 640G

High-resolution infrared camera for application in glass industry

Dimensional drawings

Dimensions: PYROVIEW 640G in compact+ housing

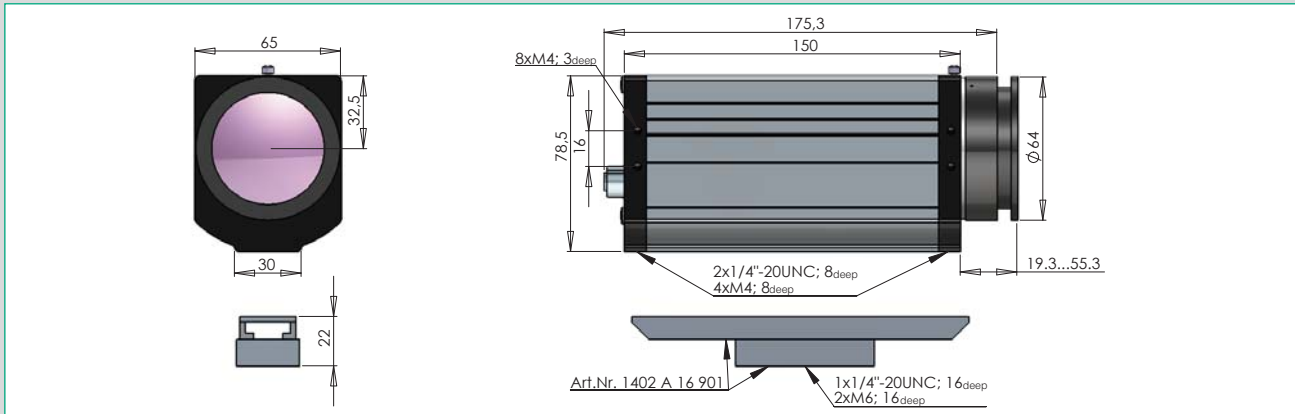

Dimensions: PYROVIEW 640G in protection housing

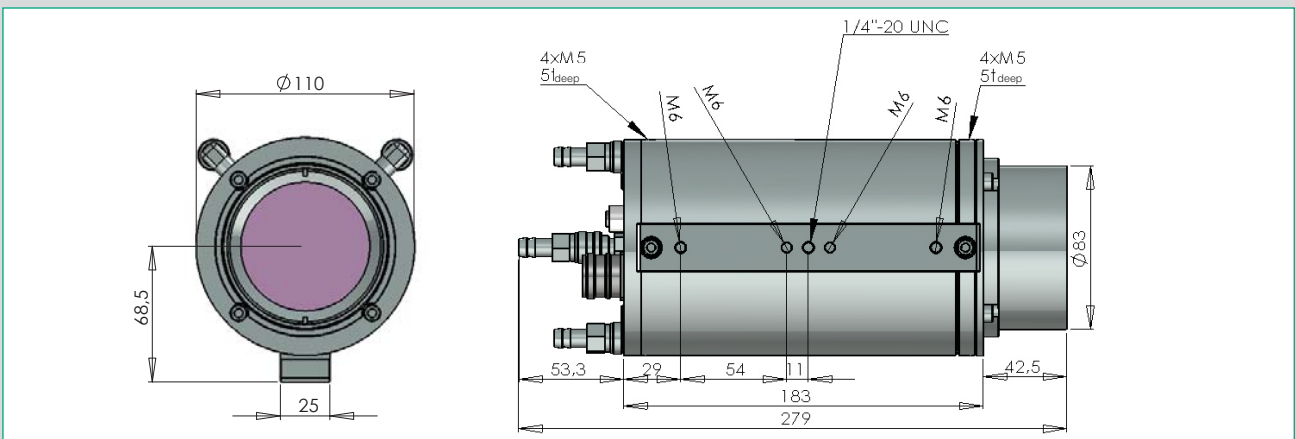

Connectors



Gigabit-Ethernet (LAN)

- Infrared real-time data up to 50 images per second (TCP/UDP)
- Web interface (status and image bar)
- PYROSOFT software
- GigE Vision® compatible
- Configuration for stand-alone operation

➔ Power supply	Error signal/
➔ Trigger 1	Alarm 1 ➔
➔ Trigger 2	Synch signal/
	Alarm 2 ➔
Inputs	Outputs

Customized terminal box

(with power supply unit, alarm relay, controller, media convertor,...)

Accessories¹

Ethernet cable (8 pin) M12-RJ45/Cross/5 m

Part number

2301A32005

Connection set for Ethernet interface 8 pin for compact+ housing

2301A04101

Mounting set for compact+ housing

1402A16901

¹ More accessories available.

PYROSOFT

Powerful online and offline software for DIAS infrared cameras

PYROSOFT Compact

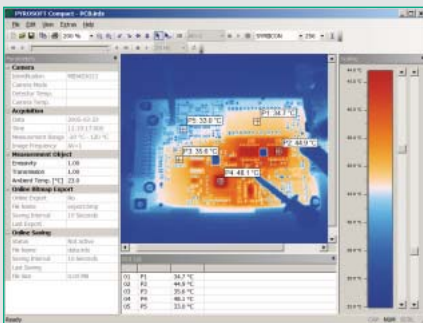

- Online data acquisition of one DIAS infrared camera
- Open and edit archived measured data and sequences
- Bitmap and video export
- Online data storage and online bitmap export
- Definition of regions of interests (ROI): points, lines and rectangle
- Generating of reports in Microsoft® Word format by integrated report function
- Context-sensitive help system (F1 key)
- Included in the scope of delivery of every PYROVIEW infrared camera

PYROSOFT Professional

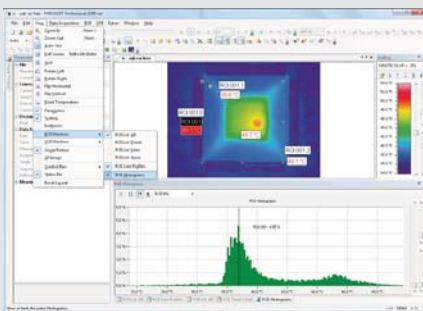

- Online data acquisition – Analyze, store and export data in real-time
- Open and edit archived measured data and sequences
- Multi document structure for several documents
- Bitmap, video and text export
- Definition of regions of interests (ROI) and values of interests (VOI) with alarm calculation, histogram and trend chart
- Numerous interface possibilities for processes (PROFIBUS, PROFINET, WAGO, TCP-Socket, Text IO)
- Reporting function, context-sensitive help system (F1 key)
- PYROSOFT Professional IO offers optionally a bidirectional data interface via PROFIBUS, PROFINET, WAGO, MODBUS, OPC, TCP Socket to process control systems, controllers and other applications

PYROSOFT Automation

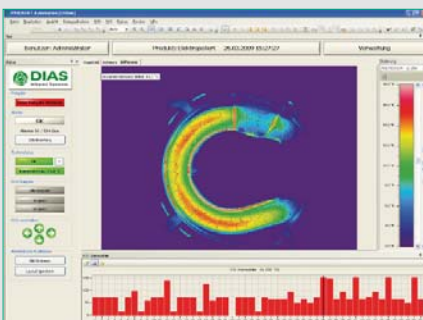

DIAS has developed the software PYROSOFT Automation for the integration of infrared cameras in automation processes.

- Comfortable product management with free definable document templates
- Product choice and release control can be made manually or automatically
- Different user levels for operator, tool setter and administrator
- Functionality of PYROSOFT Professional for administrators
- Automatic logging of system messages, measured data and alarms
- Easy to use and configurable user interface for application in fabrication
- Learning functions for automatic adjustment of alarm threshold
- Offline viewer for belated data analysis
- Bidirectional data interface via PROFIBUS, PROFINET, WAGO, MODBUS, OPC, TCP Socket to process control systems, controllers and other applications

PYROSOFT DAO

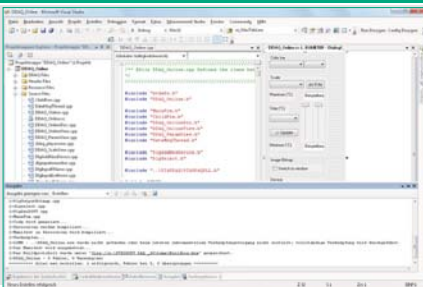

For users who want to make an integration into their software environment by themselves, we offer an own online and offline DLL interface for DIAS infrared cameras.

- API (DLL) for direct data access under Windows®
- Support for DIAS IRDX file format
- Setting of data acquisition parameters and object properties
- Query of temperature values and camera information
- Functions for displaying of images and palettes as bitmap
- Online and offline function

More software packages are available, for example:

PYROSOFT MultiCam (process software for monitoring up to 8 cameras), PYROSOFT CamZone (software for programming a stand-alone camera), application specific software like PYROSOFT FDS for DIAS fire detection systems.



We are certified for many years according to ISO 9001

Phone: +49 351 896 74-0
 Fax: +49 351 896 74-99
 E-Mail: info@dias-infrared.de
 Internet: www.dias-infrared.com

DIAS Infrared GmbH
 Pforzheimer Straße 21
 01189 Dresden
 Germany